

# GEARS AND WINCHES

## W12-R HYDRAULIC WINCH

Here in Brisbane, we manufacture these compact, versatile and heavy-duty winches.

### Specifications:

**Capacity:** 55.0 kN (12,000LB)

**Weight:** 65kg (without rope)

**Standard Ratio:** 40:1

**Rec. Wire Rope:** 30m x Ø12mm

**Max. Wire Rope:** 57m x Ø12mm

**Brake Type:** Automatic locking worm gear

**Hydraulic Oil Requirements:** 75 Litre/min @ 166 bar

**Oil Tank Capacity:** 1.2L

**Duty Cycle Per SAE J706 Section 6.2:** 42m Intermittent



*Above image is our W12-R (12,000LB Hydraulic Winch)*

### Applications:

- Tilt trays, slide backs, and recovery
- Mine sites, logging, tractors, and telecommunications
- Complies with EN14492-1 and suitable for use on Tow Trucks
- Hydraulic or Mechanical Drive
- Can be assembled right hand (R) or left hand (L)
- Lever operated Fail-Safe positive engagement free-spool, Manual or Air Clutch option
- 140mm drum diameter complying with J706 to extend rope life
- Drag brake to prevent wire rope ballooning when freewheeling
- Winch only option or complete bolt down packages available, including the mounting frame, roller fairlead, rope tensioner, various lengths of wire and synthetic rope available, connector and hook to suit
- Custom designs available to suit your requirements

Layer	Line Pull kN	Line Speed @ 75L/m Stroke m/min	Line Speed @ 60L/m Stroke m/min	Total Rope Length m
1	53.5	8.2	6.6	11.6
2	46.1	9.5	7.7	25.1
3	40.6	10.9	8.8	40.4
4	36.2	12.2	9.8	57.5

**Original Thomas Winch Manufacturer Established 1968,  
Proudly Australian and Family Owned**



**Phone:** 07 3875 1568

**Email:** admin@winch.com.au **Website:** www.winch.com.au

**Address:** 2 Coin Street Moorooka Qld 4105 **Postal:** PO Box 206 Acacia Ridge Qld 4110

## W12-R DIMENSIONS

### Hydraulic

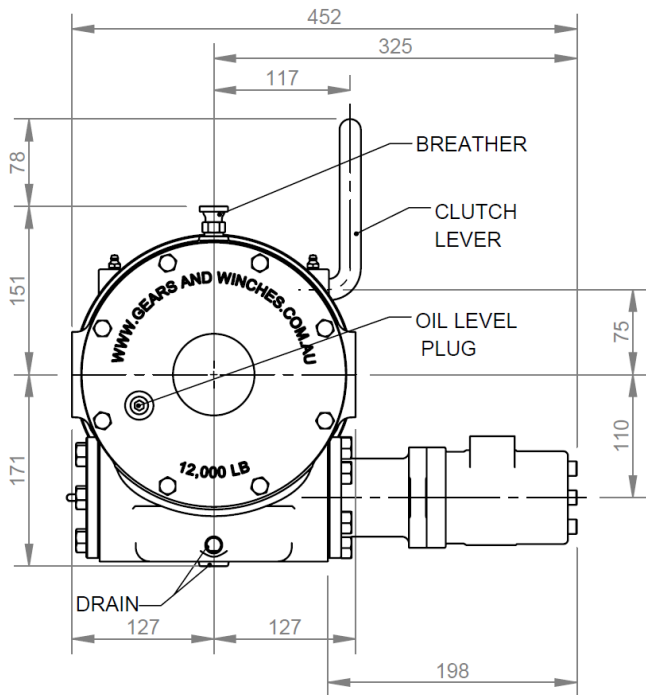

### Mechanical

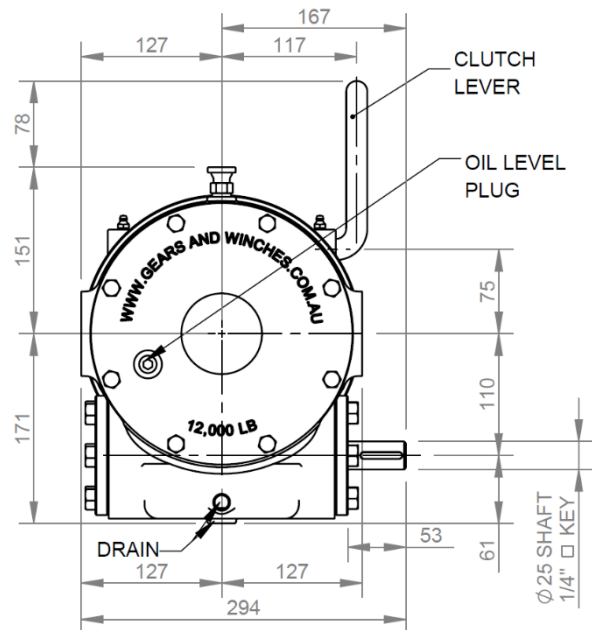

### Available Drum Lengths 192mm or 292mm

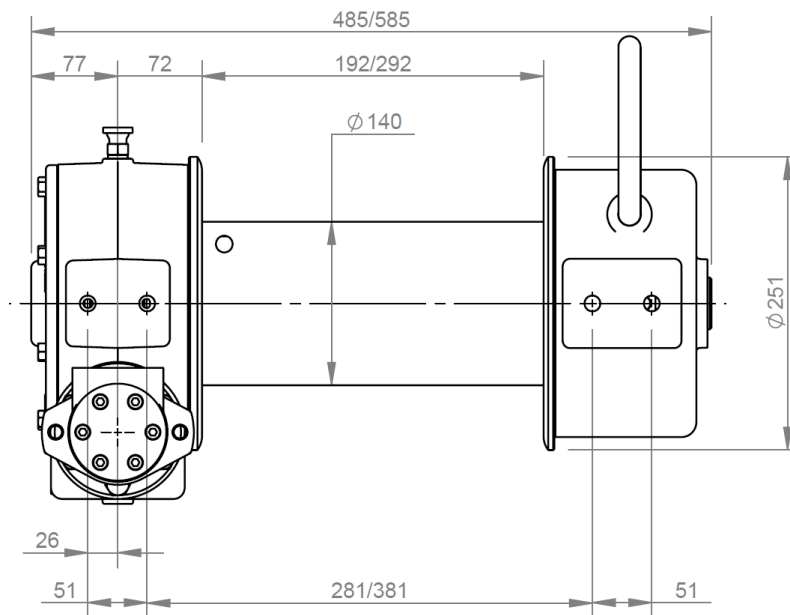

*Disclaimer: Product Dimensions are subject to change without prior notice, due to technological progress.*

**Phone:** 07 3875 1568

**Email:** admin@winch.com.au **Website:** www.winch.com.au

**Address:** 2 Coin Street Moorooka Qld 4105 **Postal:** PO Box 206 Acacia Ridge Qld 4110