

GEARS AND WINCHES

W20-R HYDRAULIC WINCH

Here in Brisbane, we manufacture these compact, versatile and heavy-duty winches.

Specifications:

Capacity: 90.0 kN (20,000LB)

Weight: 120kg (without rope)

Standard Ratio: 41:1

Rec. Wire Rope: 30m x Ø16mm

Max. Wire Rope: 90m x Ø16mm

Brake Type: Automatic locking worm gear

Hydraulic Oil Requirements: 75 Litre/min @ 175 bar

Oil Tank Capacity: 2L

Duty Cycle Per SAE J706 Section 6.2: 42m Intermittent



Above image is our W20-R (20,000LB Hydraulic Winch)

Applications:

- Tilt trays, slide backs, and recovery
- Mine sites, logging, tractors, and telecommunications
- Complies with EN14492-1 and suitable for use on Tow Trucks
- Hydraulic or Mechanical Drive
- Can be assembled right hand (R) or left hand (L)
- Lever operated Fail-Safe positive engagement free-spool, Manual or Air Clutch option
- 140mm drum diameter complying with J706 to extend rope life
- Drag brake to prevent wire rope ballooning when freewheeling
- Winch only option or complete bolt down packages available, including the mounting frame, roller fairlead, rope tensioner, various lengths of wire and synthetic rope available, connector and hook to suit
- Custom designs available to suit your requirements

Layer	Line Pull kN	Line Speed @ 75L/m Stroke m/min	Line Speed @ 60L/m Stroke m/min	Total Rope Length m
1	89.0	5.1	4.0	10.0
2	73.9	6.2	5.0	21.9
3	63.2	7.2	5.8	36.0
4	55.2	8.3	6.6	52.0
5	49.0	9.4	7.5	70.1
6	44.1	10.5	8.3	90.2

**Original Thomas Winch Manufacturer Established 1968,
Proudly Australian and Family Owned**



Phone: 07 3875 1568

Email: admin@winch.com.au **Website:** www.winch.com.au

Address: 2 Coin Street Moorooka Qld 4105 **Postal:** PO Box 206 Acacia Ridge Qld 4110

W20-R DIMENSIONS

Hydraulic

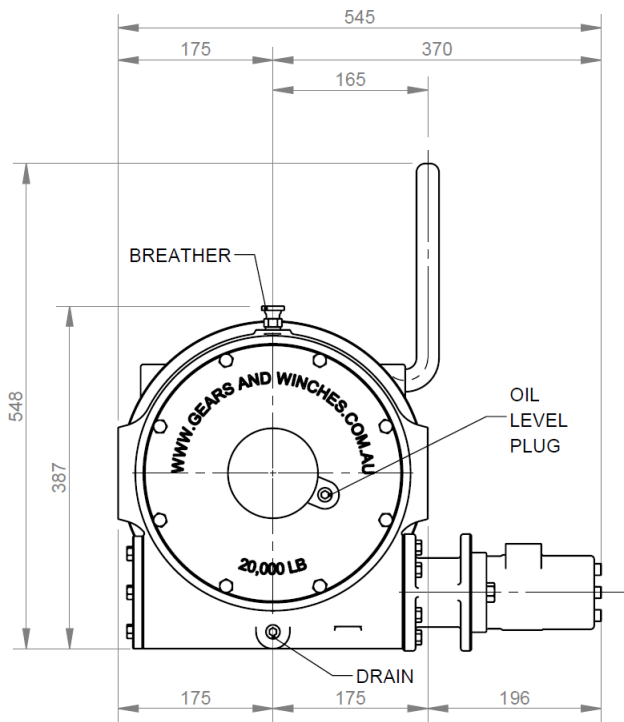

Mechanical

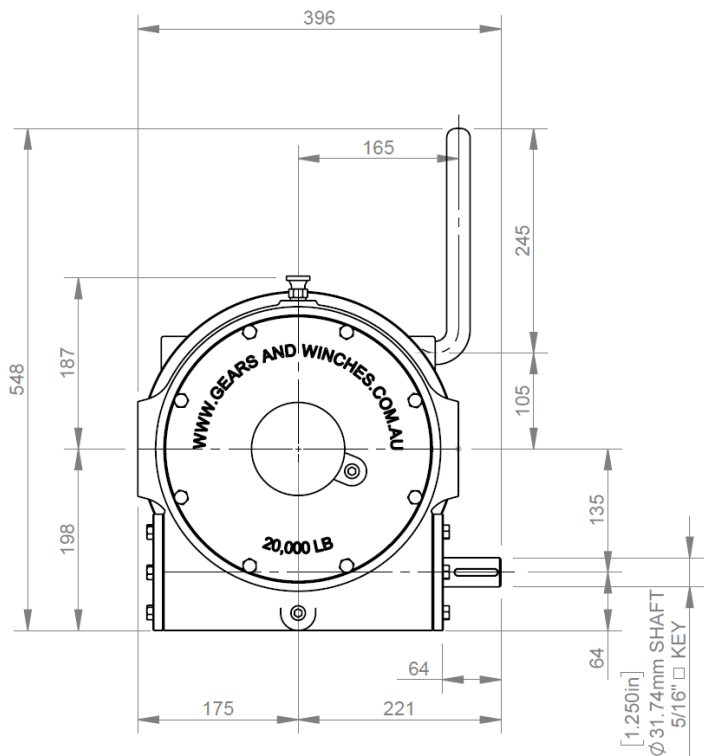

Available Drum Lengths 223mm or 323mm

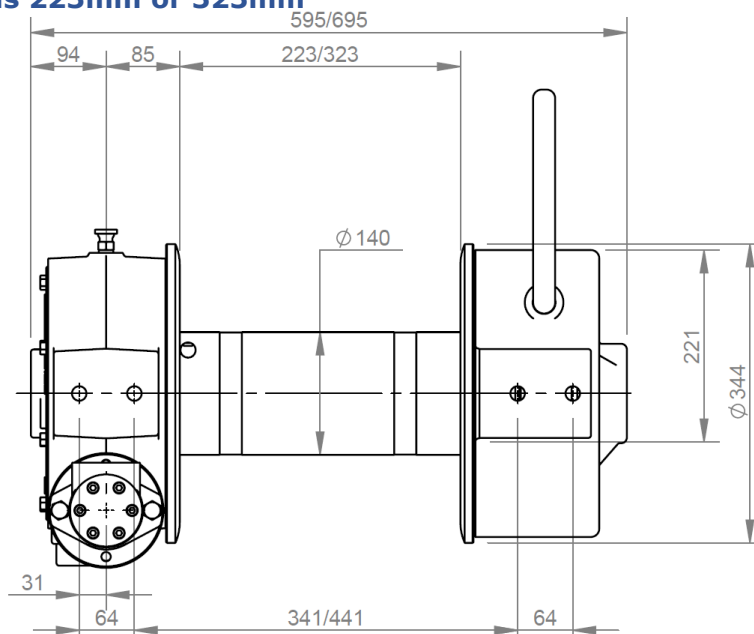

Disclaimer: Product Dimensions are subject to change without prior notice, due to technological progress.

Phone: 07 3875 1568

Email: admin@winch.com.au **Website:** www.winch.com.au

Address: 2 Coin Street Moorooka Qld 4105 **Postal:** PO Box 206 Acacia Ridge Qld 4110