

## MAG12 – 12 OR 24 VOLT ELECTRIC WINCH

Here in Brisbane, we manufacture these compact, versatile and heavy-duty winches.

### Specifications:

**Capacity:** 55.0 kN (12,000LB)

**Weight:** 45kg (without rope)

**Standard Ratio:** 570:1

**Other Ratios Available:** 61.1

**Rec. Wire Rope:** 30m x Ø10mm

**Max. Wire Rope:** 51m x Ø10mm (214mm Drum)

**Brake Type:** Automatic locking worm gear



*Above image is our MAG12 (12,000LB Electric Winch)*

### Applications:

- Tilt trays, slide backs, and recovery
- Mine sites, logging, tractors, and telecommunications
- Complies with EN14492-1 and suitable for use on Tow Trucks
- 12 or 24 Volt Electric Drive
- Lever operated dog clutch and can be assembled right hand (R) or left hand (L)
- 102mm drum diameter complying with J706 to extend rope life
- Complete with reversing solenoid control pack with plug in hand control
- Winch only option or complete bolt down packages available, including the mounting frame, roller fairlead, rope tensioner, various lengths of wire and synthetic rope available, connector and hook to suit
- Optional wireless remote control
- Custom designs available to suit your requirements

### Performance

Voltage	12 Volt		24 Volt	
<b>Bare Drum (Layer 1)</b>				
<b>Line Pull</b>	No Load	55.0 kN	No Load	55.0 kN
<b>Line Speed</b>	3.9 m/min	1.2 m/min	4.1 m/min	1.4 m/min
<b>Current</b>	50 Amps	320 Amps	30 Amps	220 Amps
<b>Full Drum (Layer 5)</b>				
<b>Line Pull</b>	No Load	37.2 kN	No Load	37.2 kN
<b>Line Speed</b>	5.8 m/min	1.8 m/min	6.1 m/min	2.1 m/min
<b>Current</b>	50 Amps	320 Amps	30 Amps	220 Amps

**Original Thomas Winch Manufacturer Established 1968,  
Proudly Australian and Family Owned**



**Phone:** 07 3875 1568

**Email:** admin@winch.com.au **Website:** www.winch.com.au

**Address:** 2 Coin Street Moorooka Qld 4105 **Postal:** PO Box 206 Acacia Ridge Qld 4110

## MAG12 DIMENSIONS

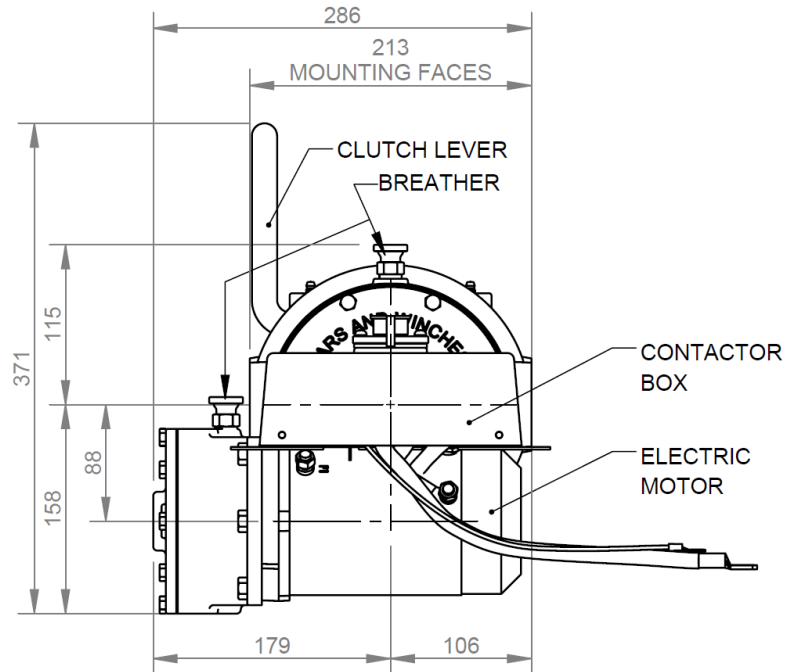

Available Drum Lengths 214mm or 291mm

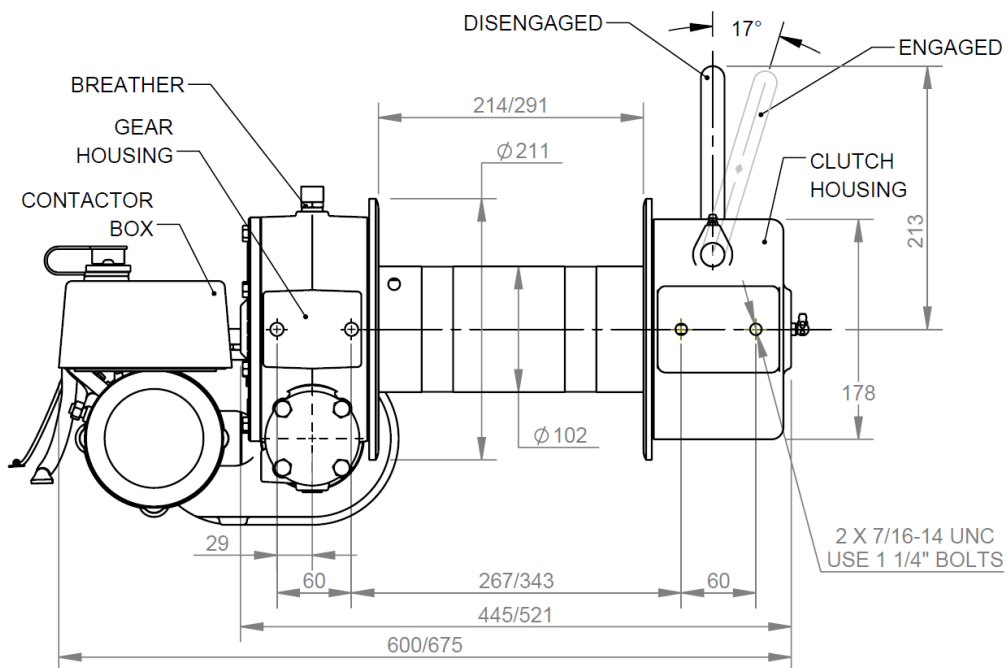

*Disclaimer: Product Dimensions are subject to change without prior notice, due to technological progress.*

Phone: 07 3875 1568

Email: [admin@winch.com.au](mailto:admin@winch.com.au) Website: [www.winch.com.au](http://www.winch.com.au)

Address: 2 Coin Street Moorooka Qld 4105 Postal: PO Box 206 Acacia Ridge Qld 4110